

MARK ARCHITECTURAL LIGHTING



BEAUTY PERFORMANCE COMMITMENT

Everything you need to light your imagination.

SLOT LED FAMILY

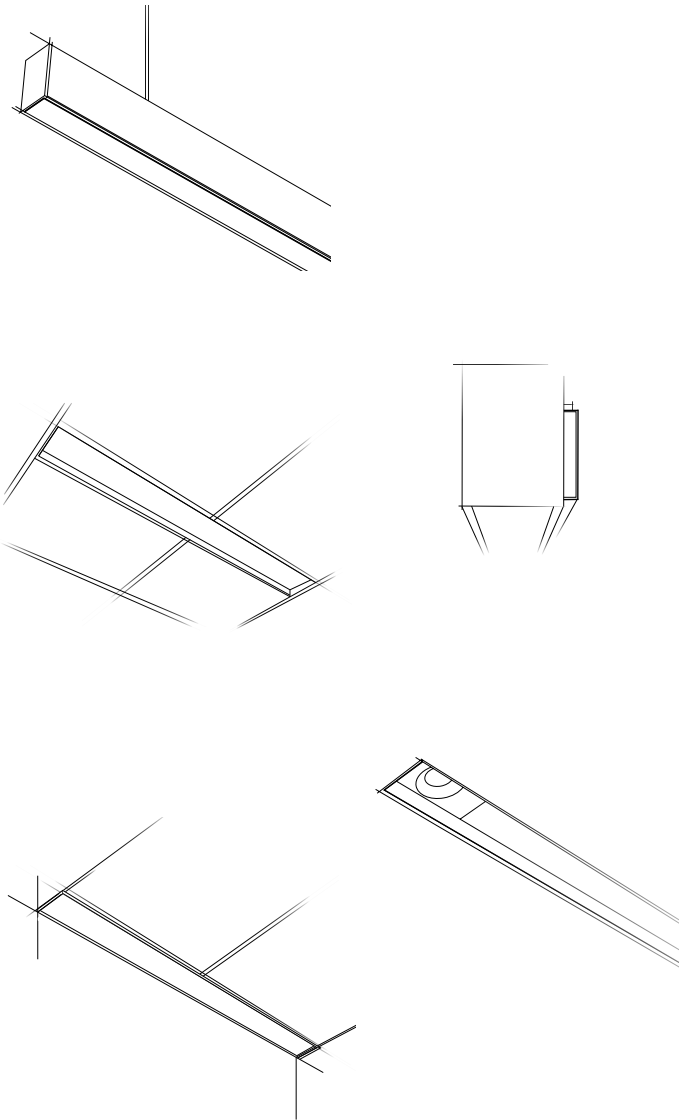

About SLOT LED

Slot LED: 2, 4, and 6

The **SLOT LED family** combines modern aesthetic elegance with unequalled performance and energy efficiency, design flexibility, seamless controls integration, and the service and support of an industry leader. In short, everything you need to light your imagination.

Fixture shown: Slot 4 LED Pendant ▶





A+ Certification for Compatible and Consistent Performance

A+ Certified solutions from Acuity Brands help you quickly and confidently select and implement lighting systems that are both compatible and consistent. For lighting professionals, it means ease, freedom and confidence that all parts of a certified lighting system will operate together.

Features

- Continuous run length increments of 1" standard ; ¼" for custom orders
- All products available as recessed fixtures, while Slot 2 and 4 are also available in pendant, surface and wall mount options
- Optional downlights provide the effect of a can light without a change in the visual feel of the ceiling
- Smooth and flicker-free dimming to 0.1%
- Configurations of Slot LED family fixtures can be part of an A+ Certified lighting system for compatible and consistent performance.

Your Vision, Realized

The clean, contemporary lines of the **Slot LED family** can either blend in quietly with the architecture or make a bold design statement. Multiple luminaire mounting options provide harmony with the physical space.

The best-in-class performance of the **Slot LED family** is a beautiful option for lighting designers who want an architecturally elegant fixture but may feel constrained by the realities of energy usage code requirements. Slot LED Family luminaires can be part of an A+ Certified* lighting system for compatible and consistent performance when nLight® enabled and configured with the optional eldoLED® driver.

Implementation, Simplified

Performance

Energy efficiency previously available only in grid fixtures. Slot LED family offers best-in-class efficacy, delivered lumens and CRI.

Beautiful Dimming

Available constant current LED drivers from eldoLED deliver smooth, flicker free dimming to 0.1%.

Integrated Controls

Acuity Brands manufactures both luminaires and controls, your assurance that everything works together perfectly from the moment of installation.

A+ Certified Systems

Configurations of Slot LED family fixtures can be part of an A+ Certified lighting system for compatible and consistent performance.

Mark 360° Total System Integration

Mark 360° is a single-source technology solution that provides greater color consistency, beautiful dimming, maximum energy efficiency and integrated system controls. All components and technologies are manufactured, warranted and supported by Acuity Brands.

On The Mark

Our most popular products can be tailored to project needs and shipped in 10 days.

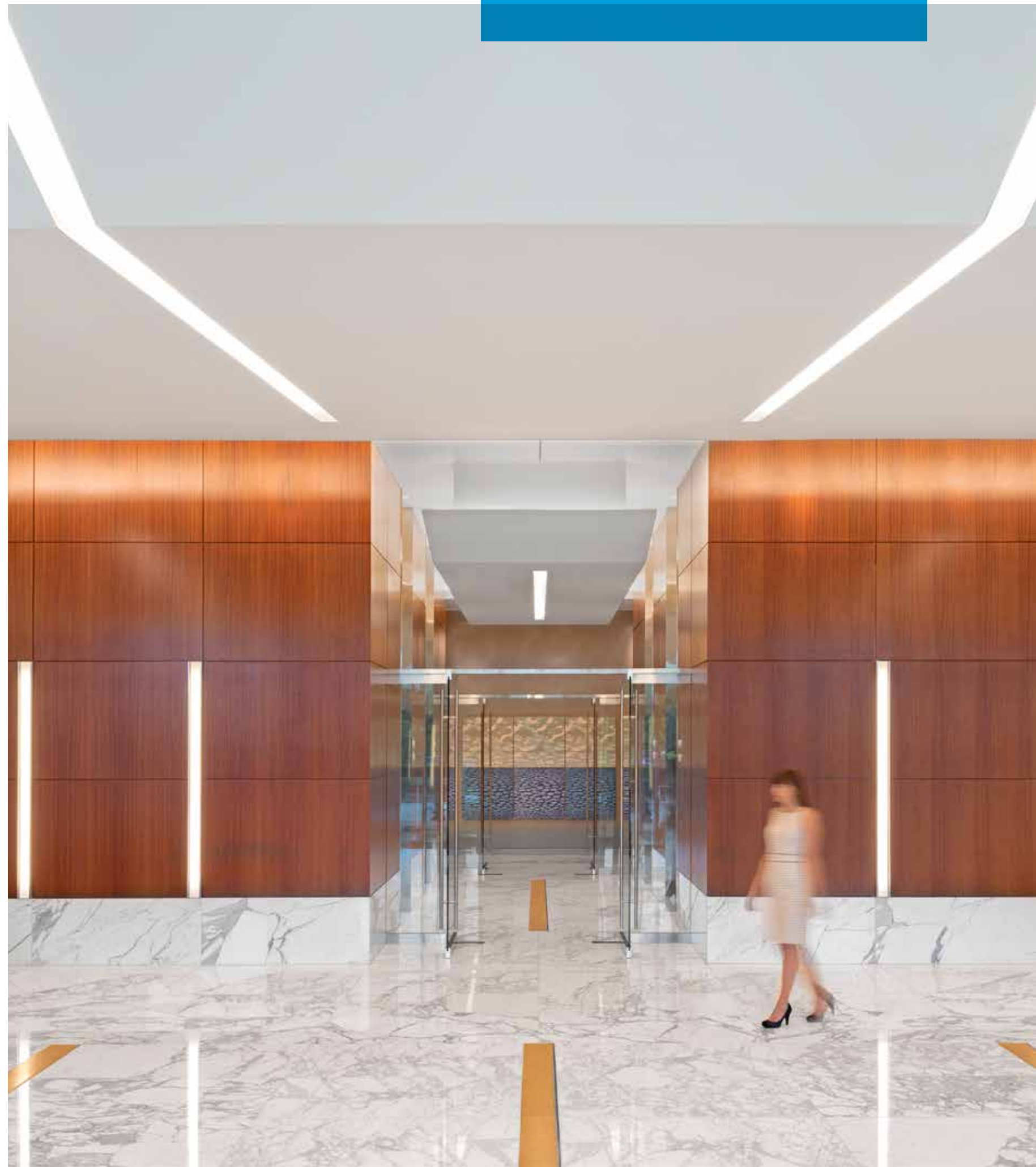

Fixture shown: CEILING: Slot 6 LED Recessed, Regressed Lens WALL: Slot 6 LED Recessed, Flush Lens ▶

Fixture shown: Slot 4 LED Recessed, Flush Lens ▶



Energy Efficiency, the Modern Way

The **Slot LED family** is a modern lighting expression that achieves energy goals previously attainable only with conventional grid lighting. Most configurations are DLC approved. With extraordinary efficacy and delivered lumens, sophisticated lines of light can now fit squarely within a project's energy budget.

What's more, **multiple lumen packages** allow fewer fixtures to deliver a desired light level, saving even more energy and lowering initial costs.



Maximize Energy Savings with nLight® Intelligent Controls

nLight is an intuitive yet complete lighting controls system that alleviates incompatibility issues and simplifies commissioning. All Slot LED family luminaires are nLight enabled to provide:

- Compatibility with the entire suite of nLight control devices—photo and occupancy detection sensors, wall-mount station controls, and more
- Digitally addressable devices capable of communicating with each other within a room, across several spaces, or throughout an entire building
- Connectivity via standard CAT-5e cabling
- True plug-and-play convenience with linked devices that automatically “discover” each other
- Anywhere/anytime remote-user access and management via nLight SensorView software that enables facility managers to optimize energy savings, perform system upgrades and conduct real-time performance analyses and reporting

AcuityControls.
nLight.

Fixture shown: Slot 4 LED Recessed Regressed Lens ▶

The Slot LED Family

Meet the updated Slot LED family, a collection of lighting solutions designed to spark your imagination.

All products feature:

- Modern design coupled with energy efficiency
- Rigorously engineered LED modules
- Multiple lumen packages
- nLight enabled controls
- Individual units, 2 to 8 ft; continuous runs in 1" increments, standard (1/4" increments, special)
- Field-replaceable LED components

Slot LED Pendant/Surface/Wall Products

Available in 2" and 4" apertures, three mounting types, three lighting distributions, and six standard lengths, these luminaires offer:

- **High Performance:** Five precision distributions (lambertian, batwing, asymmetric, wall wash and wall graze) deliver optimized light wherever it is needed. This application flexibility is further enhanced with multiple lumen packages
- **Superior Color and Quality:** Rigorously engineered LED modules and optional downlights provide exceptional quality lighting
- **Seamless Controls Integration:** nLight lighting control options provide daylight dimming, occupancy detection and constant lumen management
- **Simplified Installation:** Patent-pending Slot AEL 3-step fixture-to-fixture connection method
- **Wet Location Rating*:** Slot LED recessed with flush lens is wet location rated; all other Slot LED luminaires are rated for use in damp locations

* Note: downlights are not wet location rated.

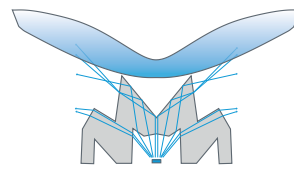

Batwing

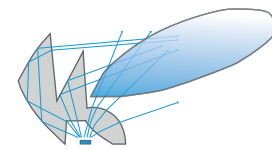

Asymmetric Half Batwing

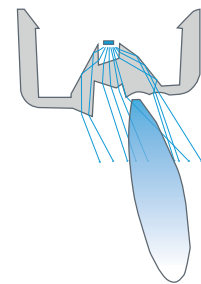

Wall Wash

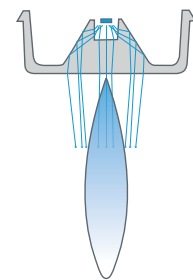

Wall Graze

lumenDIRECTIR optics for Pendant, Surface, Wall, and Recessed Wallwash

Slot LED's patent-pending, precision lumen DIRECTIR optics condition and refract light to deliver accurately controlled, striation-free, and uniform white light.

RECESSED			
	SLOT 2 LED	SLOT 4 LED	SLOT 6 LED
Lumen Output	RLP/ FLP	RLP/ FLP	RLP/ FLP
Delivered Lumens(/ft)	400 LMF	382 / 438	448 / 468
	600 LMF	549 / 629	652 / 692
	800 LMF	716 / 819	736 / 842
	900 LMF		856 / 916
	1000 LMF	885 / 1011	909 / 1040
	1200 LMF		1061 / 1042
Efficacy (l/W)	76 - 93	88 - 108	101 - 116
CCT options	3000	3000	3000
	3500	3500	3500
	4000	4000	4000
Dimming (std / opt)	1% / 0.1%	1% / 0.1%	1% / 0.1%
CRI (std / opt)	80 / 90	80 / 90	80 / 90
Downlight (opt)*	NO	YES	YES
Trim Options	Trimless (sheetrock), Center and Perimeter Mount in 5/8" Flange (Sheetrock) or 9/16" Flat or Inverted Tee		

RLP = Regressed Lens; FLP = Flush Lens

* Downlight available in multiple CCT choices. Consult spec sheets.

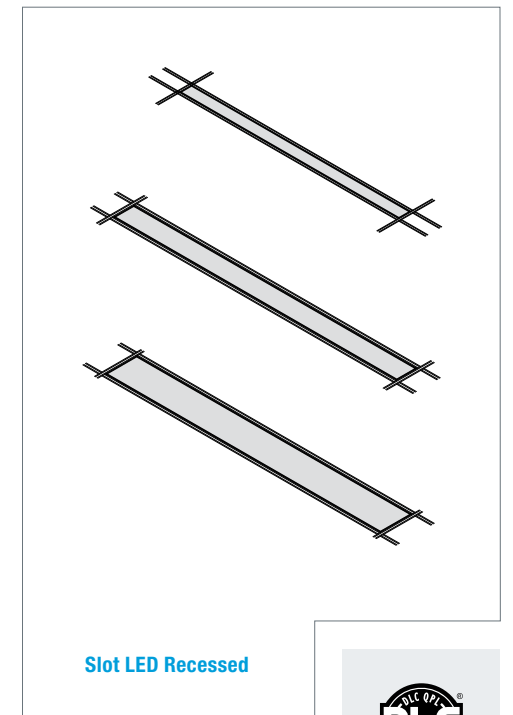

Slot LED Recessed

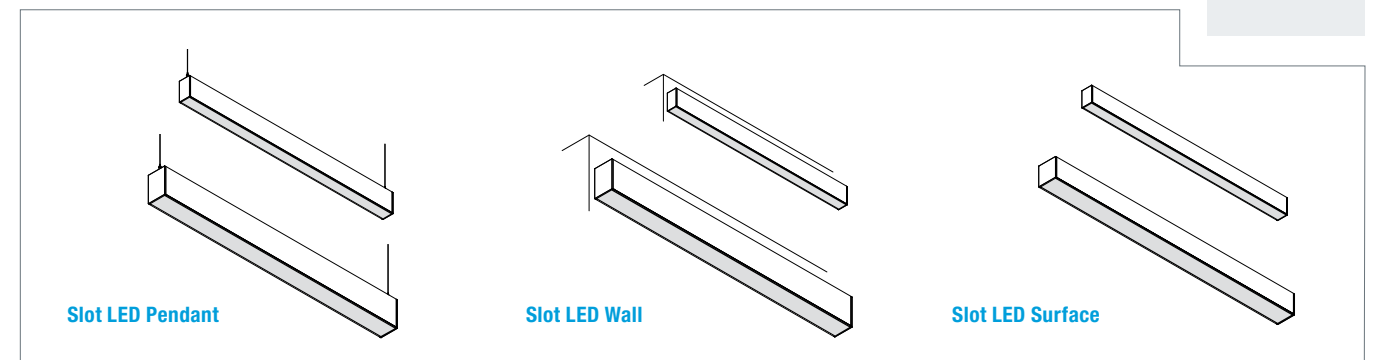

Slot LED Pendant

Slot LED Wall

Slot LED Surface

	SLOT 2 LED			SLOT 4 LED		
	PENDANT	SURFACE	WALL	PENDANT	SURFACE	WALL
Lumen Output	Norm / Hi	Norm / Hi	Norm / Hi	Norm / Hi	Norm / Hi	Norm / Hi
Delivered Lumens	Direct	524 / 1048	515 / 1030	511 / 1022	585 / 1170	575 / 1150
	Indirect	643 / 1287	----	702 / 1404	658 / 1316	714 / 1427
	Direct - Indirect		----			
	direct	517 / 1068	----	519 / 1038	565 / 1181	586 / 1173
	indirect	654 / 1318	----	705 / 1411	654 / 1326	706 / 1412
	Efficacy (l/W)	78 - 108	74 - 76	73 - 113	89 - 110	84
CCT options	3000	3000	3000	3000	3000	3000
	3500	3500	3500	3500	3500	3500
	4000	4000	4000	4000	4000	4000
Dimming (opt)	0.10%	0.10%	0.10%	0.10%	0.10%	0.10%
CRI	80	80	80	80	80	80
Downlight (opt)*	x	x		x	x	

* Downlight available in multiple CCT choices. Consult spec sheets.

At Mark Architectural Lighting, our passion is collaborating with the discerning lighting designer and the meticulous engineer. Our comprehensive portfolio of state-of-the-art products combines elegant aesthetics and industry-leading performance, and we consistently delight our customers with tailor-made modifications and customized products. Mark Lighting helps you make great design happen... turning your vision into reality easier, faster and more beautifully than ever.

5-year limited warranty. Complete warranty terms located at www.acuitybrands.com/CustomerResources/Terms_and_conditions.aspx

Notes: 1. Specifications subject to change without notice 2. Actual performance may differ as a result of end-user environment and application

*Voluntary certifications pending



eldoLED



MARK ARCHITECTURAL LIGHTING™

marklighting.com 3 Kilmer Rd, Edison NJ 08817 T (732) 985 2600
F (732) 985 8441

©2015 Acuity Brands Lighting, Inc. All Rights Reserved. We reserve the right to change design, materials and finish in any way that will not alter installed appearance or reduce function and performance. All trademarks referenced are the property of their respective owners.

